

Produkt



LCD/TFT

Decknhalter: DTD 7561 SL C

Artikelnummer: 1052

Technische Daten

maximale Belastbarkeit:	20 kg
Verfügbare Farben:	chrom
TÜV/GS-Zulassung:	nein
Standart Garantie:	2 Jahre

Technische Zeichnung

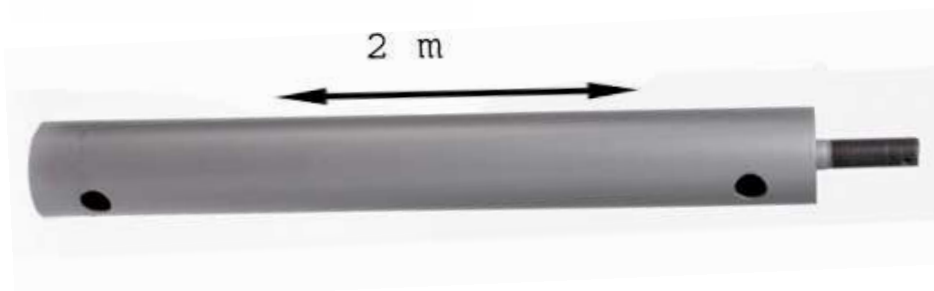
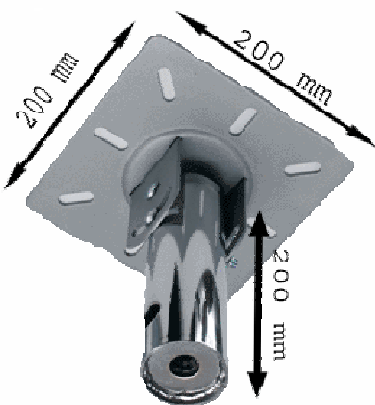

Adresse:

Roland Walter
Heinrich-Hertz-Str. 5
86179 Augsburg

Kontakt:

Tel: 0821 – 88 86 33
Fax: 0821- 81 51 145

Internet:

www.wandhaltershop.de
email: re-mote@re-mote.com

Bankverbindung

Stadtsparkasse Augsburg
BLZ: 720 500 00
KTO: 240 373 555

Inhaber: Walter Roland

Es gelten unsere AGB's

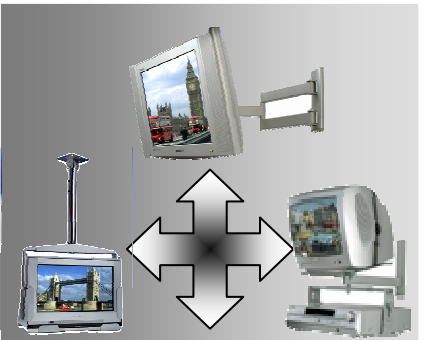

TV - Halter

Monitor - Halter

LCD - Halter

Rollwagen

TFT – Halter

Drehteller

Beamer - Halter

Plasma – Halter

Explosions- Zeichnung zu Artikel 1052

DOUBLE LCD VESA MOUNT ADAPTOR FOR 60MM DIAMETER TUBE METRIC VERSION WITH M16 ALLEN SCREW

PLEASE KEEP THIS PARTS LIST FOR FUTURE REFERENCE
FOR MOUNTING VESA STANDARD FIXINGS 75MM / 100MM

PARTS LIST

Part Number	Part Name	Quantity
1	VESA MOUNT	1
2	SPRING CLIP	1
3	M4 x 10mm SCREW	8
4	M3 ALLEN KEY (fits M4 Allen screw)	1
5	M18 x 50mm ALLEN BOLT	1
6	ø25mm WASHER	1
7	M14 ALLEN KEY (fits M16 Allen bolt)	1

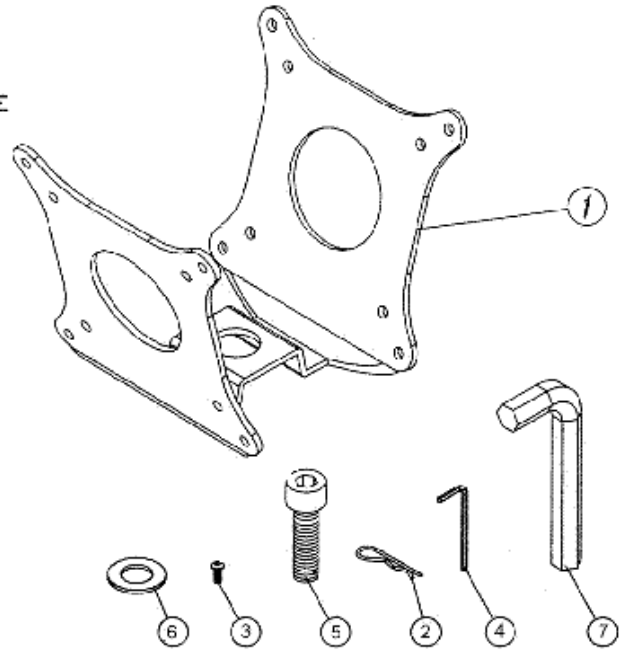

Number	Part Name	Quantity
1	CEILING MOUNT PLATE (200mm x 200mm)	1
2	200mm EXTENSION TUBE (60mmØ)	1
3	M8 COACH BOLT	2
4	M8 NUT	2
5	ø19mm WASHER	2
6	ø60mm WASHER	1
7	M8 NUT COVER	2
8	M16 x L75mm SCREW	1
9	SPRING CLIP	1
10	ALLEN KEY	1
11	WASHER ø38mm	1
12	COVER PLATE	2

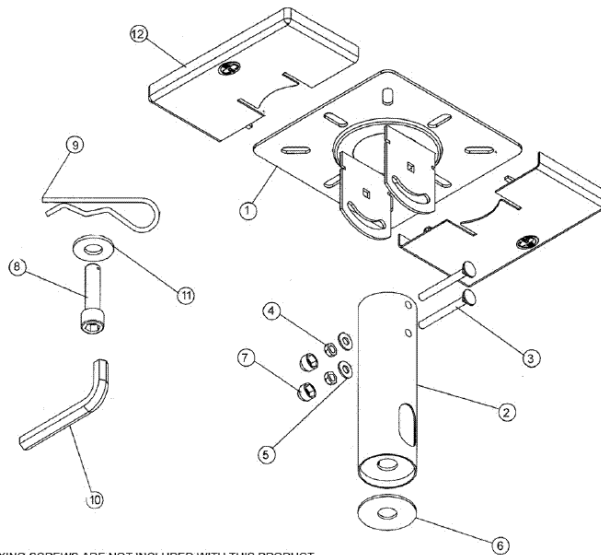

Part Number	Part Name	Quantity
1	2 METRE ø 60mm POLE	1
2	WASHER	1
3	M16 x L50mm ALLEN SCREW	1
4	M14 ALLEN KEY	1
5	RUBBER RETAINING RING	1
6	SPRING CLIP	1

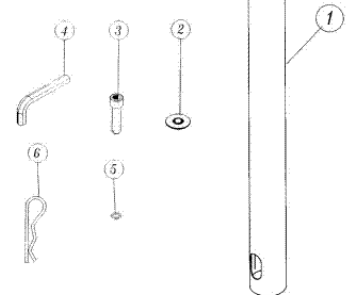

IMPORTANT : PLEASE NOTE THAT WALL / CEILING FIXING SCREWS ARE NOT INCLUDED WITH THIS PRODUCT.
B-TECH HIGHLY RECOMMENDS THAT THIS PRODUCT SHOULD BE INSTALLED BY A PROFESSIONAL.
THE INSTALLER MUST SATISFY THEMSELVES THAT ALL FIXING SCREWS ARE SUITABLE FOR INSTALLING THIS MOUNT.
PLEASE PAY CAREFUL ATTENTION TO WHERE THIS MOUNT IS LOCATED. SOME WALLS / CEILINGS ARE NOT SUITABLE FOR INSTALLATION.
WHEN DRILLING HOLES IT IS PARTICULARLY IMPORTANT TO TAKE CARE OF ELECTRICAL CABLES, WATER OR GAS PIPES IN THE WALL.